

Application guidelines

# Danfoss scroll for refrigeration LLZ for parallel applications

50 - 60 Hz - R404A - R507





<b>General overview .....</b>	<b>4</b>
Scope .....	4
Benefits .....	4
<b>Oil management concept .....</b>	<b>5</b>
Active systems.....	5
Passive systems.....	6
<b>Operating conditions .....</b>	<b>8</b>
Power supply .....	8
Compressor ambient temperature .....	8
Operating envelope.....	8
Refrigerants and lubricants.....	8
Discharge temperature protection.....	8
High and low pressure protection .....	8
Cycle rate limit.....	8
<b>System design recommendations.....</b>	<b>9</b>
Essential piping design considerations.....	9
Expansion device .....	10
Suction accumulator.....	10
Suction header.....	10
Oil level regulator .....	11
Oil separator / oil reservoir.....	12
Oil separator / Oil reservoir for active system.....	12
Economizer for parallel vapour injection compressors .....	14
Refrigerant charge limits.....	14
<b>Installation and service .....</b>	<b>15</b>
Piping design.....	15
Wiring and rotation direction .....	15
Failure analysis .....	15
<b>Sound and vibration management .....</b>	<b>16</b>
Running sound level.....	16
<b>Ordering information .....</b>	<b>17</b>
<b>Parallel units LLZ013-15-18-24.....</b>	<b>18</b>
Composition of LLZ013-024 uneven tandem/ trio/quadro .....	18
Composition of LLZ013-024 even tandem.....	18
Compressor mounting.....	19
Suction and discharge connection .....	20
Oil equalisation connection.....	20

**Scope**

The application guidelines describe the operating characteristics, design features and application requirements for LLZ parallel compressors in low temperature refrigeration applications. They apply to both standard and economized compressors.

To ensure proper parallel installation and running conditions, the following recommendations must be followed:

- It is essential to follow all the instructions given in these guidelines, the instruction leaflet delivered with each compressor and the Selection & Application Guidelines for single compressors.

- For additional system components related to specific application requirements, the supplier's recommendations must always be followed.

---

**Benefits**

Parallel compressor installation' refers to a system of interconnected compressors with a common suction line and common discharge line. The technique of mounting compressors in parallel is also referred to as manifolding. In a system with only two compressors, this is referred to as a tandem configuration.

The main reason for manifolding is reduced operating cost through greater control of capacity and power consumption. This is achieved by staggering the compressor switch-on sequences that allow the parallel system to match its power with the capacity needed.

A second reason for manifolding is improved part load efficiency. In a parallel installation the individual compressor(s) can be switched off while the other compressor(s) keep operating at 100% load. Therefore the part load efficiency is very near the full load efficiency. Conventional fixed-speed compressor unloading methods impose a serious penalty on part load efficiency, mainly at low load conditions.

Suction gas in a hermetic scroll compressor flows via the oil sump, which makes it more difficult to maintain equal pressure in the sumps of parallel compressors. Since oil equalisation usually depends on equal sump pressures, this is a point of special attention. Danfoss Commercial Compressors have developed specially adapted oil management systems which ensure proper

oil balancing between the compressors, but it is always recommended to carry out some tests to validate oil balancing in the system.

To ensure suitable oil distribution, both passive and active types of systems are introduced into LLZ compressors.

**Active systems**

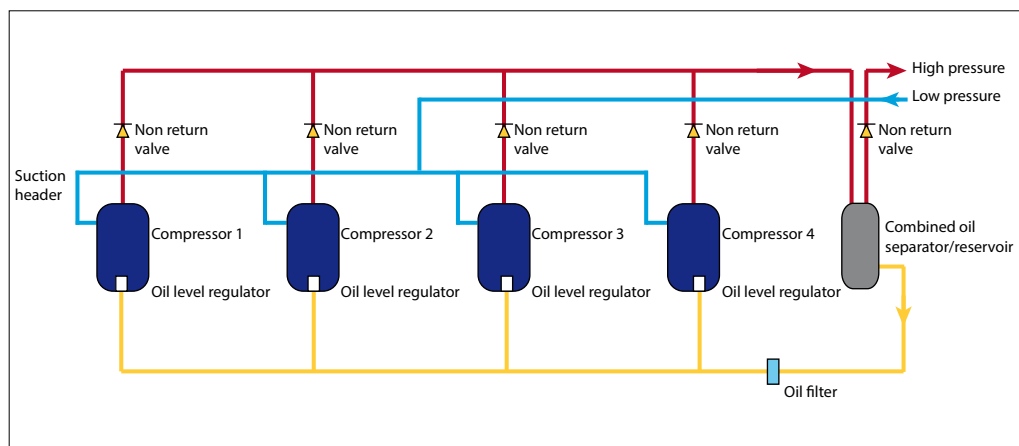

An active system can offer more flexible and efficient oil management. It is highly recommended for manifolding since this positive system increases the reliability of the manifolding configuration. Oil management will be secured mainly by the oil level regulator and the oil separator, which can supply the oil when required. The active system can thus accommodate itself to various oil conditions.

**Danfoss has qualified tandem / trio / quadro composition for active systems.**

For manifolding with more than two compressors, it is always suggested to use a

suction header. Each compressor will equip the oil level regulator to facilitate the oil level balance.

To avoid refrigerant back flow from high pressure, it is always recommended to have a non-return valve on the discharge line of each compressor, as well as one non-return valve on the outlet of the oil separator in the system to prevent refrigerant migration.

For more details on the oil separator/reservoir and oil level regulator please refer to the "System design recommendation" in this guideline.

**Passive systems**

A passive system is an oil management system without any measurement or control devices such as oil level regulators and oil controllers. By contrast, a solution equipped with such measurement or control devices is called an active system.

**Danfoss has qualified only the even tandem (two same compressors) for passive solutions.**

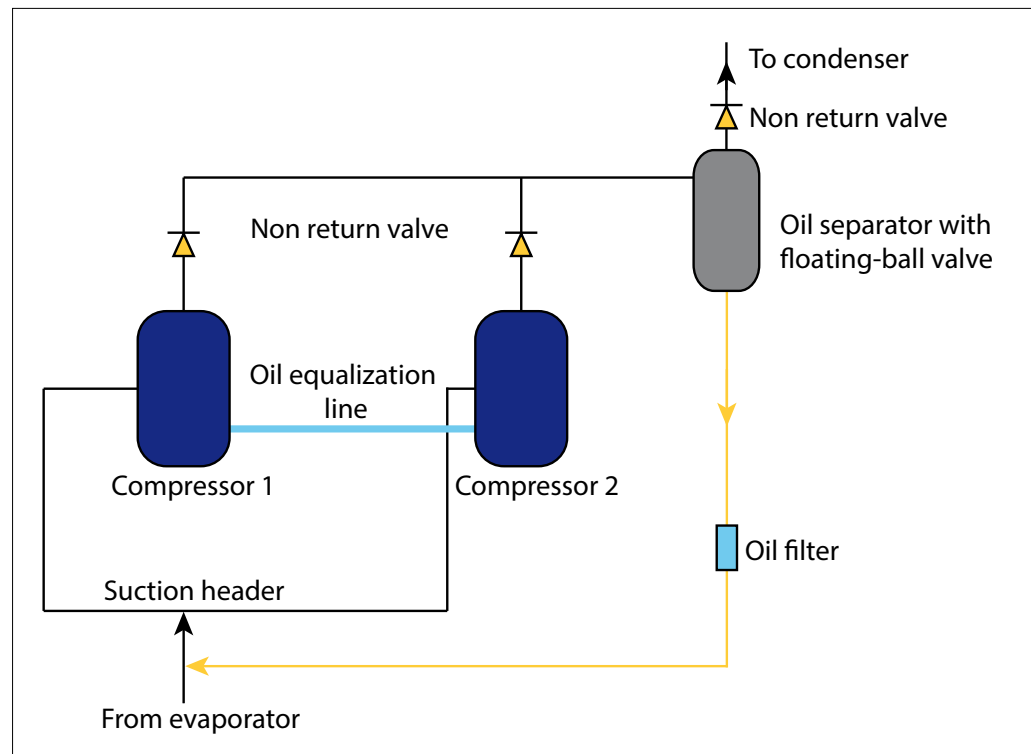

This is one of the simplest and cheapest ways of manifolding compressors. It is very popular in air-conditioning applications, but in refrigeration this kind of system needs to be paid special attention due to severe operating conditions.

**Danfoss has qualified only the even tandem (two same compressors) for passive solutions.** Compressor sumps and low-pressure shells are interconnected. An interconnecting pipe on the lower part of the compressor (installed on the existing oil sight glass) ensures oil balancing. The suction header design is critical, as it ensures a pressure drop balancing and an equal distribution of oil returning from the system when both compressors are running.

The success of such a system relies very much on the sizing and design of the pipe work, as small differences in sump pressure can result in significant oil level variations. This system needs perfect suction tube balancing.

For an LLZ even tandem, oil return can be secured by an oil separator with float ball valve, which will return the oil to the main suction line. The oil equalisation line goes through the oil sight glass with an adaptor on the standard compressor. To avoid refrigerant back flow from high pressure, it is always recommended to have a non-return valve on the discharge line of each compressor, as well as one non-return valve on the outlet of the oil separator in the system to prevent refrigerant migration.

The following are recommendations from Danfoss application engineering for connecting low temperature compressors using an oil equalisation line system without active control:

Danfoss could provide piping drawings for even tandem passive system, please contact Danfoss for more information.

- An adequately (generously) sized suction header is needed to provide for equal distribution of returning refrigerant gas and oil to each individual compressor; also the suction header should be installed horizontally.

- To secure sufficient oil return to the compressor, Danfoss suggests below dimension requirement of the suction header:  $H > 5D$ .

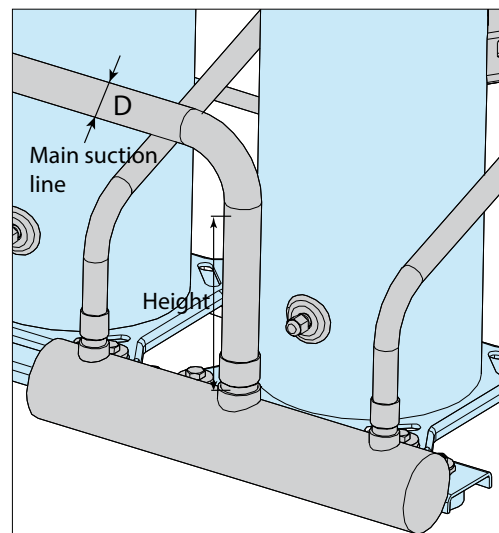

- The oil equalization tube is recommended to have an outer diameter of 1/2".

- If the unit runs in a very cold situation, both compressors need to be switched on after a period of single running for better oil circulation, especially in low load conditions.

- Care must be taken to mount all the compressors on the same horizontal level and also to provide adequate liquid flood back protection when using this method.

## Application Guidelines

## Operating conditions

### Power supply

LLZ compressors can be operated at nominal voltages as indicated below. Under-voltage and over-voltage operation is allowed within the indicated voltage ranges. In case of risk of

undervoltage operation, special attention must be paid to current draw. LLZ scroll compressors are available in four different motor voltages.

		Motor voltage code 2	Motor voltage code 4	Motor voltage code 7	Motor voltage code 9
Nominal voltage	50 Hz	200-220 V - 3 ph	380-415 V - 3 ph	-	-
Voltage range	50 Hz	180 - 242 V	342 - 456 V	-	-
Nominal voltage	60 Hz	208-230 V - 3 ph	460 V - 3 ph	575 V - 3 ph	380 V - 3 ph
Voltage range	60 Hz	187 - 253 V	414 - 506 V	517 - 632 V	342 - 418 V

### Compressor ambient temperature

LLZ scroll compressors can be applied from -35°C to 50°C ambient temperature. The compressors are designed as 100% suction gas cooled without the need for additional fan cooling.

Ambient temperature has very little effect on the compressor performance. For detailed information please refer to "the "LLZ application guidelines".

### Operating envelope

The recommended parallel assemblies design from Danfoss Commercial Compressors have been qualified to ensure there is no impact on the compressor operating envelope.

More details can be found in the "LLZ application guidelines".

### Refrigerants and lubricants

Approved refrigerants and lubricants for LLZ single compressors are also allowed for parallel

assemblies. For more details, please refer to the "LLZ application guidelines".

### Discharge temperature protection

The discharge gas temperature of each compressor must not exceed 135°C.

the compressor against operations beyond its specific application envelope.

DGT protection is required if the high and low-pressure switch settings do not protect

More details can be found in the "LLZ application guidelines".

### High and low pressure protection

The pump-down pressure switch must have a set point slightly higher than the lowest compressor safety pressure switch set point. The compressor switch must never be bypassed and shall stop all the compressors. The high-pressure safety pressure switch shall stop all the compressors.

compressor auto-restart caused by LP safety switch settings to fewer than 3 to 5 times during a 12-hour period.

Whenever possible (i.e. PLC control) it is recommended to limit the possibility of

Please refer to the "LLZ application guidelines" for recommended settings.

### Cycle rate limit

The system must be designed in a way that guarantees a minimum compressor running time of two minutes so as to provide for sufficient motor cooling after start-up along with proper oil return. Note that the oil return may vary since it depends upon system design.

the service life of the motor-compressor unit. If necessary, place an anti-short-cycle timer in the control circuit, then connect as shown in the wiring diagram in the Danfoss Scroll compressor application guidelines. A three-minute (180-second) time-out is recommended.

There must be no more than 12 starts per hour (6 when a resistor soft-start accessory is introduced); a number higher than 12 reduces

Danfoss recommends a restart delay timer to limit compressor cycling.



**Essential piping design considerations**

Proper piping practices should be employed to ensure adequate oil return, even under minimum load conditions, with special consideration given to the size and slope of the tubing coming from the evaporator. Tubing returns from the evaporator should be designed so as not to trap oil and to prevent oil and refrigerant migration back to the compressor during off-cycles.

If the evaporator lies above the compressor, the addition of a pump-down cycle is strongly recommended. If a pump-down cycle were to be omitted, the suction line must have a loop at the evaporator outlet to prevent refrigerant from draining into the compressor during off-cycles.

If the evaporator is situated below the compressor, the suction riser must be trapped to ensure the oil return to the compressor (see fig.1).

When the condenser is mounted at a higher position than the compressor, a suitably sized "U"-shaped trap close to the compressor is necessary to prevent oil leaving the compressor from draining back to the discharge side of the compressor during off-cycle. The upper loop also helps avoid condensed liquid refrigerant from

draining back to the compressor when stopped (see fig. 2). The maximum elevation difference between the indoor and outdoor section cannot exceed 8 m. System manufacturers should specify precautions for any applications that exceed these limits to ensure compressor reliability.

Economiser heat exchanger piping shall be arranged in a counter flow of gas and liquid to assure optimum heat transfer and therefore best subcooling effect.

Piping should be designed with adequate three-dimensional flexibility (figure 2). It should not be in contact with the surrounding structure, unless a proper tubing mount has been installed. This protection proves necessary to avoid excess vibration, which can ultimately result in connection or tube failure due to fatigue or wear from abrasion. Aside from tubing and connection damage, excess vibration may be transmitted to the surrounding structure and generate an unacceptable sound level within that structure as well (for more information on sound and vibration, see the section on "Sound and vibration management").

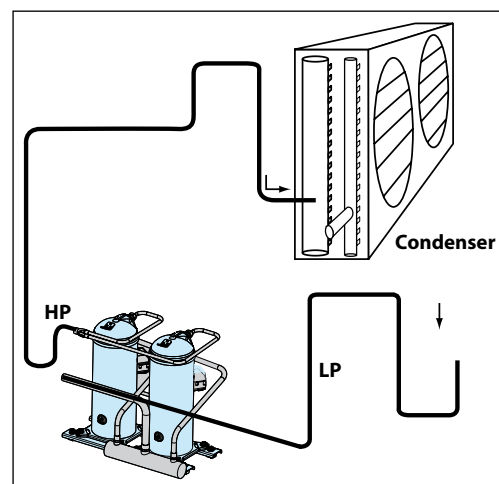
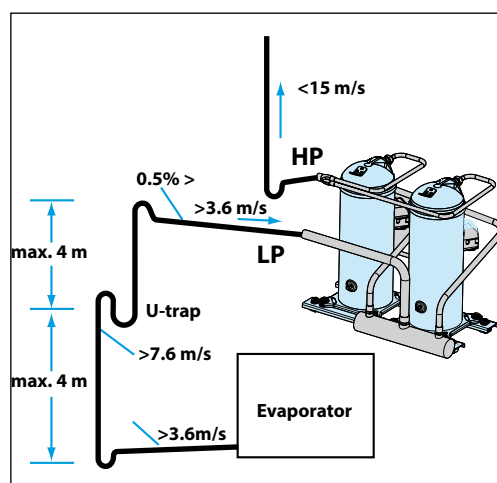

To ensure proper refrigerant and oil circulation, the speed limits in all pipes are generally recommended as follows:

- For horizontal/vertical discharge gas velocity: no more than 15m/s;
- For vertical suction gas velocity: no less than 7.6m/s;

- For horizontal suction gas velocity: no less than 3.6m/s;
- For horizontal/vertical liquid velocity: around 1.5m/s;
- For suction header gas velocity: no more than 4m/s.

**Expansion device**

When the parallel installation is serving a single evaporator system, the dimensioning of the expansion device (thermostatic or electronic) becomes critical and must be made in relation to both minimum and maximum capacity. This will ensure correct superheat control in all situations, with a minimum of 5K superheat at the compressor suction. The expansion device should be sized to ensure proper control of the refrigerant flow into the evaporator. An oversized valve may result in erratic control. Proper selection could imply a slightly undersized expansion valve at full load. This consideration is especially important in manifolded units

where low load conditions may require the frequent cycling of compressors. This can lead to liquid refrigerant entering the compressor if the expansion valve does not provide stable refrigerant superheat control under varying loads. The superheat setting of the expansion device should be sufficient to ensure proper superheat levels during low loading periods. A minimum of 5K stable superheat is required. In addition, the refrigerant charge should be sufficient to ensure proper subcooling within the condenser so as to avoid the risk of flashing in the liquid line before the expansion device.

**Suction accumulator**

The refrigeration compressor is designed to compress vapour only. A suction line accumulator prevents compressor damage from a sudden surge of liquid refrigerant and oil that could enter the compressor from the suction line. For low temperature application, suction accumulator is a must unless approved by careful tests under different operating conditions.

Selection of a suction line accumulator should be made on the basis of the following three capabilities:

1. The accumulator should have an adequate liquid-holding capacity that can vary with the

system. Normally this should not be less than 50% of the system charge. If possible, this value should be checked based on actual tests.

2. The accumulator should perform without adding excessive pressure drop to the system.

3. An accumulator should have the capability of returning oil at the proper rate and under a range of load conditions.

Guideline of suction accumulator needs to be respected in making a selection.

**Suction header**

For efficient oil management in parallel systems the oil should return to the compressor at approximately the same rate as it leaves so that an appropriate oil level can always be maintained.

Danfoss recommends an adequately sized suction header which provides equal distribution of returning refrigerant and oil to each individual

compressor. The suction lines from the header towards each individual compressor must be fitted into the suction header. This configuration will result in a higher gas velocity at the pick-up tube inlet and proper oil return when the oil level in the suction header rises. The compressor suction lines must always enter the suction header on the topside. A recommended suction header design is shown below.

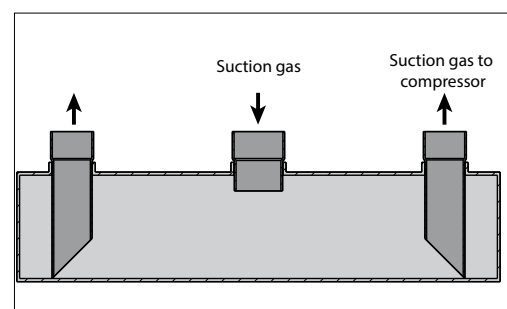
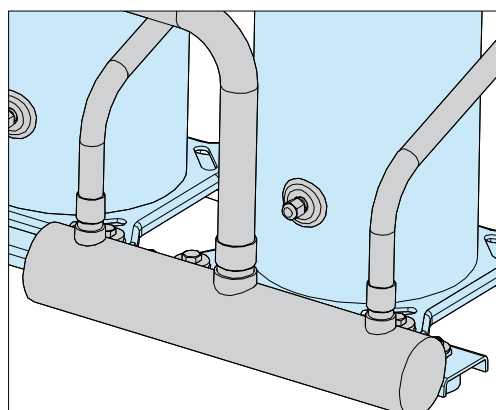

To ensure ideal pressure equalization, the suction header must be symmetrical and the lines from the suction header to each compressor must be short and identical. These recommendations are not so critical when using an active system.

Danfoss recommends the following as necessary for secure a suction header installation:

- The suction header should be adequately sized

for equal distribution of returning refrigerant gas and oil to each individual compressor; also the suction header should be installed horizontally.

- The gas velocity in the suction header must be a maximum of 4 m/s.
- The suction line and the suction header must be insulated to limit suction gas superheat.

**Oil level regulator**

Oil level regulator monitors the oil level and controls oil injection by switching the solenoid valve on and off to maintain an acceptable oil level in the compressor the crankcase. When crankcase oil level cannot be restored within a period of time (setting value), the alarm contactor will be activated and stop the compressor to protect it from damage (some oil level regulator do not have an alarm function).

According to the function, there are three types of oil level regulator: electronic, electromechanical and mechanical. For a high-pressure oil reservoir system, Danfoss recommends individual electronic oil control regulators over the mechanical float ball oil regulator system for effective oil regulation. For the a low-pressure system, all types are allowed.

Danfoss has qualified the below oil level regulators. Due to various operations in refrigeration systems, the customer needs to verify the configuration specified for their own solutions.

• TEKLAB:  
TK3-DANF-R01: Danfoss recommends this kind of Oil level regulator for its overall quality. It can judge the oil level precisely even when there is some oil foaming. The total time before the alarm is four minutes with the new control module, which is suitable for LLZ compressors. The adaptor of TEKLAB perfectly matches the oil sight glass fitting of LLZ compressor. A filter is needed before Oil level regulator.

• Henry AC&R:  
OP-02: The action and control logic works well with LLZ compressors, while adaptors can fit, but not very well, with the oil sight glass fitting. A filter is needed before oil level regulator.

Note: Customers must refer to the manufacturer's guidelines on oil level regulators for proper set-up and operation.

**Oil separator / oil reservoir**

**Oil separator for passive system**

The role of the oil separator is to intercept the mixed oil from the compressed refrigerant gas and returns it back to the compressor to assure efficient lubrication of its moving parts, and also to improve the system heat exchangers' efficiency. In our manifolding system, the oil separator is installed in the compressor discharge line as shown below.

No oil separator category is included in this guidelines. For more details, please refer to the manufacture's guidelines.

Regarding passive solutions, it is recommended to use an oil separator with a floating-ball valve. The floating-ball valve can control the oil flow and act as a capillary in the oil return line; therefore, there is no need to install an oil capillary in the system.

**Passive system**

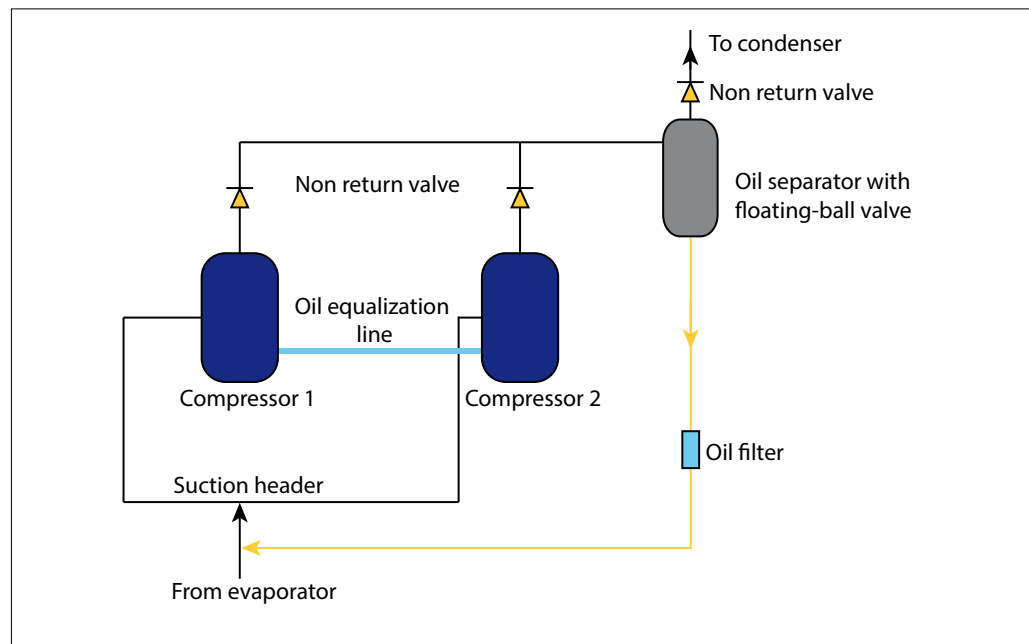

**Oil separator / Oil reservoir for active system**

When an active system is adopted by the customer, the oil separator is always considered together with oil reservoir.

Due to system design, loads and defrost cycles, etc, there will be varying amounts of oil returning to the oil separator. Because of this, a safety reserve of oil is required for successful operation of the active system.

**Active system**

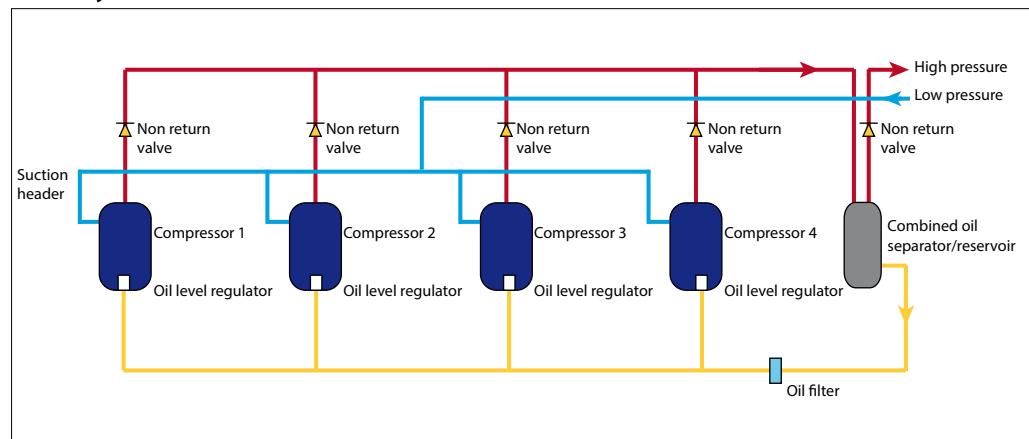

**High pressure oil reservoir (combined oil separator/oil reservoir)**

Danfoss recommends that high-pressure systems are configured in active solutions. These systems store the oil in a common oil separator / reservoir at compressor discharge pressure (see the figure below). The advantage is that these systems do not need a separated oil reservoir but make use of a combined oil separator / reservoir arrangement, which normally results in a cost saving over traditional low-pressure systems.

From an application point of view, high-pressure systems are more critical than traditional low pressure systems and care must be taken to make sure that the separator / reservoir installed is of sufficient size and oil content (as per manufacturer's recommendation) so that there is always oil stored. And pay special attention to avoid discharge gas entering the compressor oil sump, which could lead to some negative effects such as higher discharge and oil temperatures, less lubrication capability and the loss of efficiency due to hot-gas bypass.

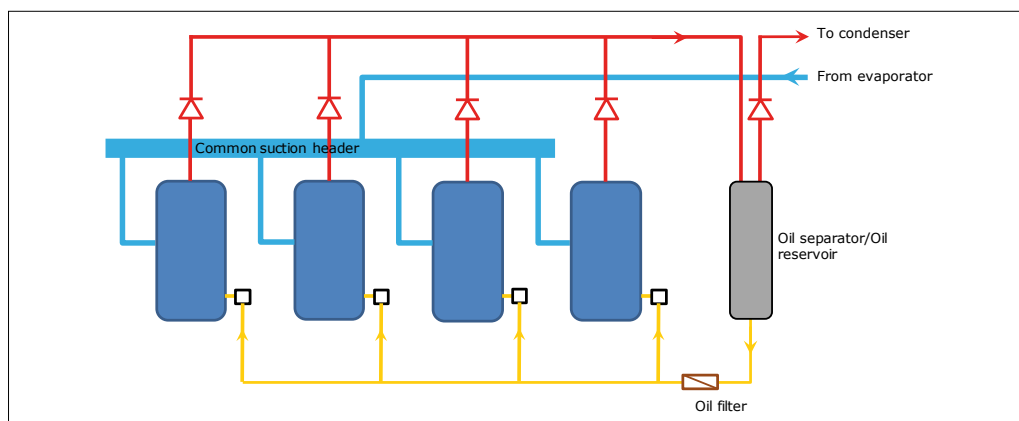

Active solution with high pressure oil reservoir (combined oil separator/oil reservoir)

**Low pressure oil reservoir with separate oil separator**

Usage of an oil reservoir is very common in low-pressure systems to control the variations in oil quantity during operation (see below). In this configuration, the oil reservoir is maintained at a pressure slightly above the compressor suction pressure using a differential pressure valve (check

valve). Therefore, the amount of refrigerant dissolved in the oil will be limited. The pressure drop is low when the oil enters the compressor and the amount of flash gas formed in the sump is small. The differential pressure required for sufficient oil flow from the oil reservoir to the compressor is system specific, depending upon the application and components chosen.

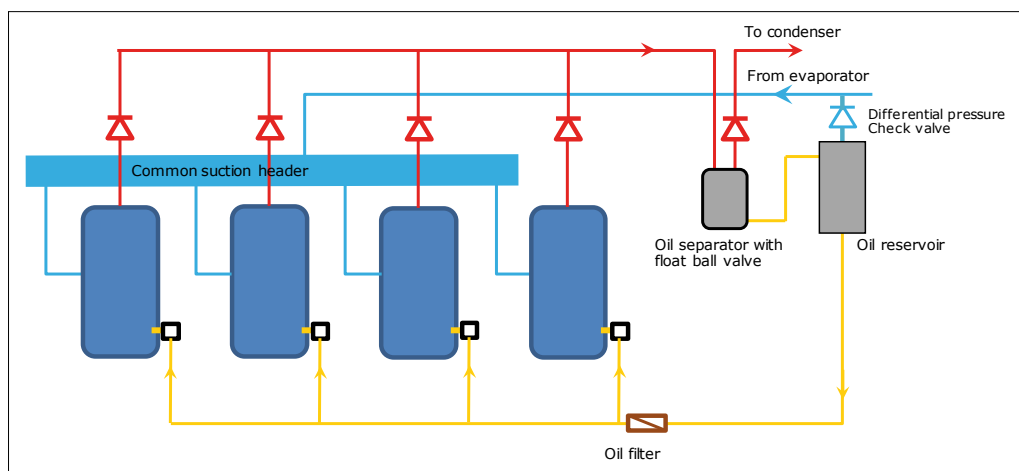

Active solution with low pressure oil reservoir

In brief, oil separator and oil reservoir are always considered together regarding active system.

For active solution with high pressure oil reservoir system it is recommended to use oil separator(no float ball valve) with oil stored function. In other words, a combined oil separator/oil reservoir. For low pressure oil

reservoir system, it is recommended to work together with oil separator which with float ball valve.

Generally Danfoss recommend to use high pressure oil reservoir system (one oil separator with oil reserve function).

Danfoss has qualified the below oil separator. Due to various applications in refrigeration systems, the customer needs to verify the

configuration specified for their own solutions. Please refer to oil separator's guideline for more information.

**Passive solution**

Country*	CN	NAM/CN	NAM/CN	EMA	EMA	EMA
Company	Fasike O&F	Emerson ALCO	Henry AC&R	Frigomec	Frigomec	Carly
Model	F-65	A-WE	S-CE	SO/ERS	SO/ER	Turboil-F for PVE oil
Type	Filter	Impingement	Impingement	Filter	Filter-demister	Centrifugal

Note\*: The countries listed here only indicate whether the product is available in local country or not for now. Regardless the availability, all the OS above has been qualified by Danfoss under certain configuration.

**Active solution**

Country*	CN	EMA	EMA
Company	Fasike O&F	Frigomec	Carly
Model	F-66Q	SRO/ERS	Turboil-R for PVE oil
Type	Centrifugal Oil-stored	Filter Oil-stored	Centrifugal Oil-stored

Note\*: The countries listed here only indicate whether the product is available in local country or not for now. Regardless the availability, all the OS above has been qualified by Danfoss under certain configuration.

**Economizer for parallel vapour injection compressors**

A single economiser (heat exchanger) can be applied in a parallel economiser configuration. A system may use one economizer with a single circuit on the liquid line and multiple circuits

on the vapour side. In the case of refrigerant being fed into the injection port of a stationary compressor, a non return valve should always be fitted.

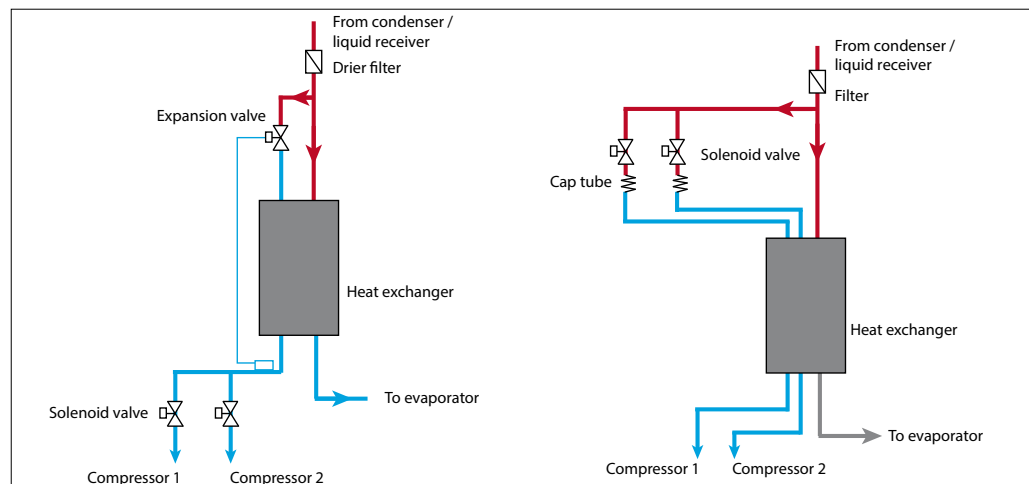

**Refrigerant charge limits**

If refrigerant charge exceeds the limit, a liquid receiver and suction accumulator will be essential to ensure that the system runs reliably.

Compressor models		Refrigerant charge limit(kg)
Tandem	LLZ013-015-018	5.9
	LLZ024	9.4
Trio	LLZ013-015-018	7.7
	LLZ024	12.3
Quadro	LLZ013-015-018	10.0
	LLZ024	16.0

**Piping design**

Due to the various LLZ parallel configurations, Danfoss only provides an even tandem piping design. For uneven, trio and quadro active systems, the customer can make their own design based on the velocity limits.

For each tandem configuration specific outline drawings are available as indicated on the following pages. These drawings must always be followed.

No changes shall be made to the indicated tubing diameter and fitting types. As for passive systems, the oil equalisation line shall be made of copper tube and assembled in such a way so that it does not extend above the connection height and must be horizontal so as not to trap oil.

Please contact Danfoss Sales for specific drawings.

---

**Wiring and rotation direction**

All compressors in a tandem unit must be electrically wired individually.

Compressors should run with the correct rotation direction. This can be achieved by having the correct phase sequence on each compressor motor terminal (L1-T1, L2-T2, L3-T3).

---

**Failure analysis**

When one compressor in a parallel system fails, the chance of foreign particles entering other compressors is greatly increased. Therefore a

failure analysis must be done quickly to ensure further proper running conditions for the overall installation (i.e.: oil analysis).

**Running sound level**

Average sound levels below is at ARI LBP condition

Model	50Hz		60Hz	
	Sound power(dBA) Without jacket	Sound power(dBA) With jacket	Sound power(dBA) Without jacket	Sound power(dBA) With jacket
LLZ013 tandem	80	72	82	74
LLZ015 tandem	82	74	85	77
LLZ018 tandem	85	75	86	76
LLZ024 tandem	87	77	88	78



To build a complete tandem, one must order two compressors and the tandem kit. Danfoss LLZ compressors can be ordered in either industrial packs or in single packs. Please refer to the single

compressor application guidelines for ordering. All LLZ tandem configuration will share the same tandem kit.

Kit code number 120Z5073

	Designation	Qty
1	Flat washer	8
2	Spacer	8
3	Rotolock sleeve	2
4	Rotolock nut	2
5	Adaptor	2
6	O-ring	2
7	Teflon seal	2

**Composition of LLZ013-024 uneven tandem/trio/quadro**

**These compositions can only work with active systems.**

based on the velocity the limits in "Essential piping design" section. And Customers need to do their own validation.

Danfoss will not provide drawings for these configurations. Pipe sizes can be calculated

**Composition of LLZ013-024 even tandem**

**Active system**

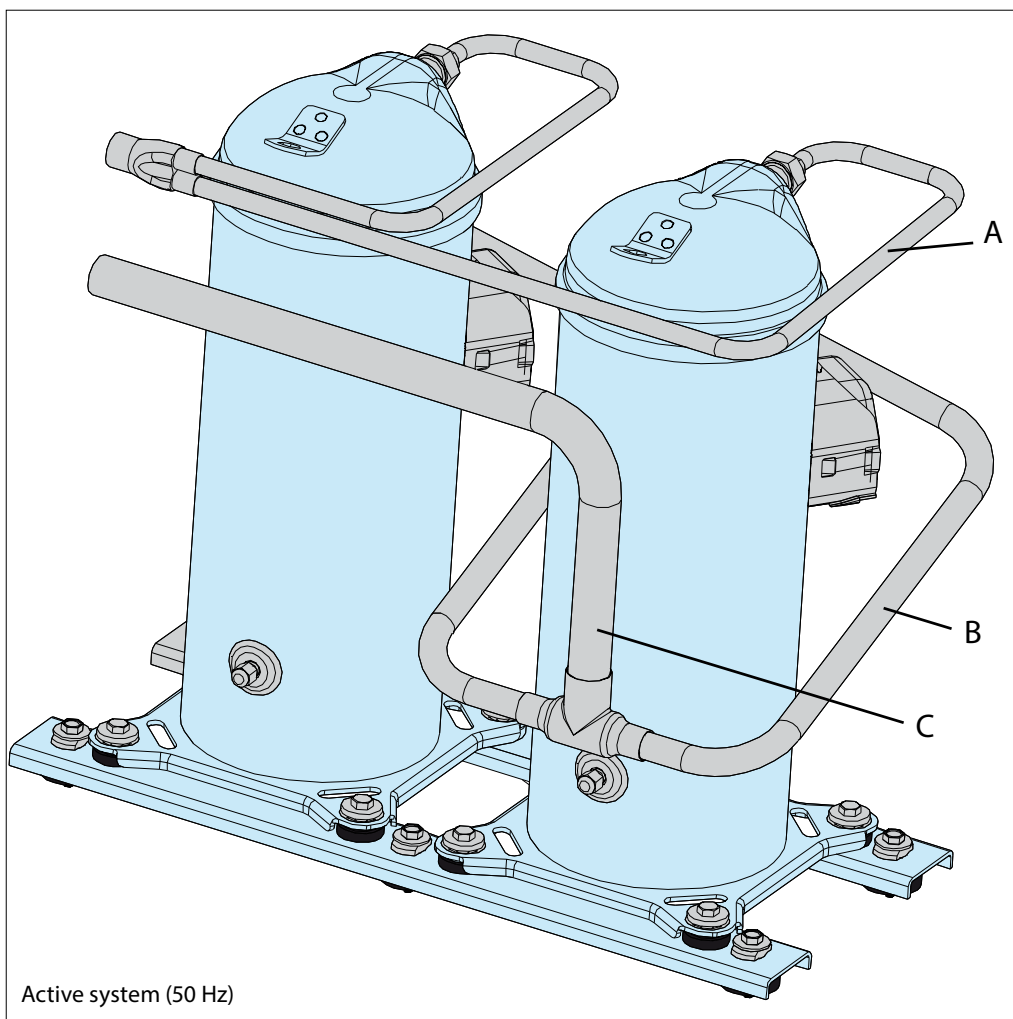

Tandem model	A	B	C
LLZ013-018	1/2"	3/4"	1"1/8
LLZ024	3/4"	1"1/8	1"3/8

For more details, please refer to drawing 0ZZ0218B(50Hz).  
Note: the dimensions are external diameters

Passive system

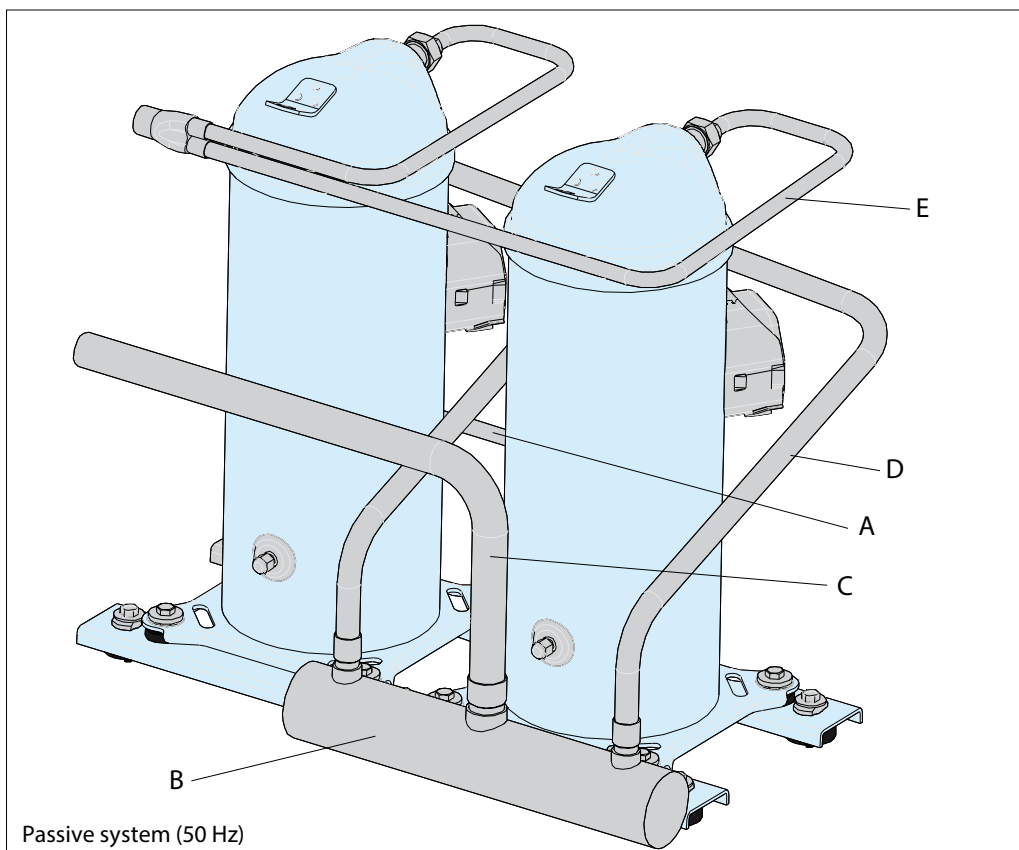

Passive system (50 Hz)

Tandem model	A	B	C	D	E
LLZ013-018	1/2"	Ø64.00	1 1/8"	3/4"	1/2"
LLZ024	1/2"	Ø79.38	1 3/8"	1 1/8"	3/4"

For more details, please refer to drawing 0ZZ0217B(50Hz).  
 Note: the dimensions are external diameters

Compressor mounting

The tandem is fixed on the frame using the flexible grommets supplied with the compressor.

The compressors are fixed on the rails (not supplied) using flat washers ① rigid spacer ② included in the "tandem kit" reference 120Z5073 (to be ordered with the compressors). An additional rigid spacer ③ (mounting kit for single compressors) must be placed under the rail grommets (see below drawing).

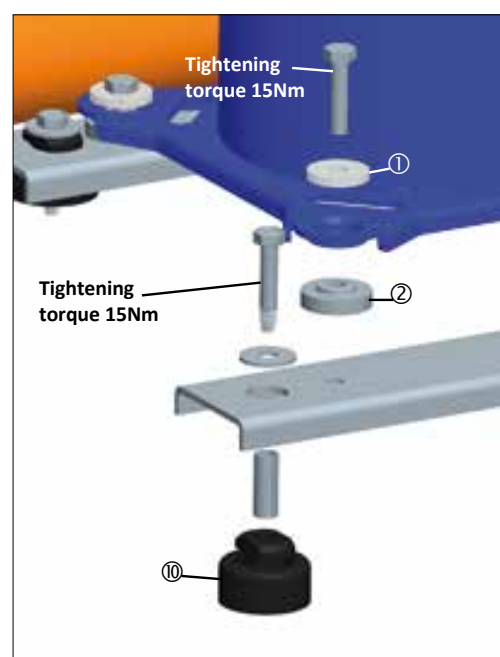

**Suction and discharge connection**

Both suction and discharge line go through a rotolock connection. Pipes ③ are brazed to the sleeve ③' and fixed to the compressor with nuts ④'.

Note: sleeve ③' and nut ④' are the supplied with LLZ single service kit (120Z5067-LLZ013/015/018 and 120Z5068-LLZ024).

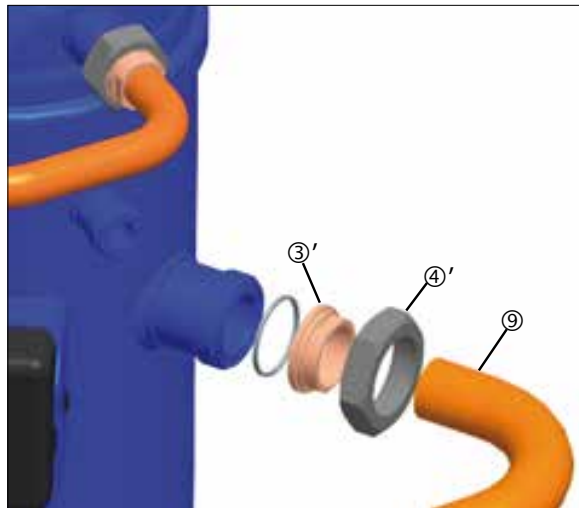

Suction line

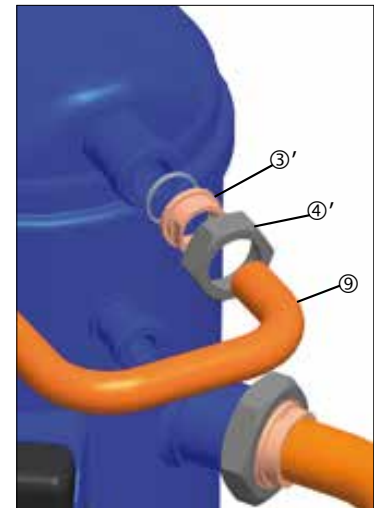

Discharge line

**Oil equalisation connection**

As for passive systems, an oil equalisation line ⑤ is brazed to the sleeve ③.

A rotolock nut ④ fixes the sleeve ③ and adaptor ⑤, which is connected with oil sight glass port ⑧. The O-ring ⑥ and Teflon ring ⑦ guarantee the seal.

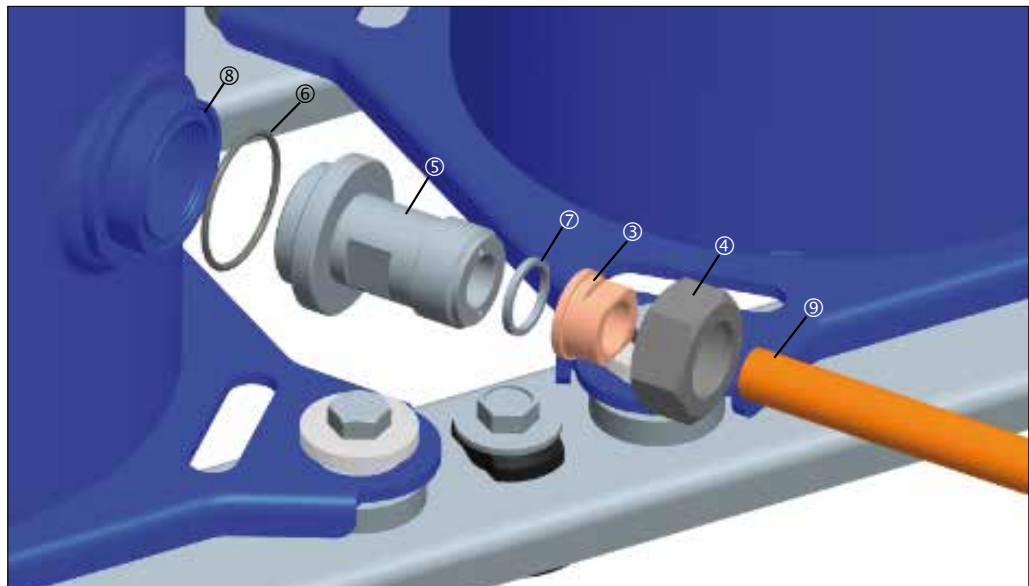





Danfoss Commercial Compressors is a worldwide manufacturer of compressors and condensing units for refrigeration and HVAC applications. With a wide range of high quality and innovative products we help your company to find the best possible energy efficient solution that respects the environment and reduces total life cycle costs.

We have 40 years of experience within the development of hermetic compressors which has brought us amongst the global leaders in our business, and positioned us as distinct variable speed technology specialists. Today we operate from engineering and manufacturing facilities spread across three continents.



Danfoss Inverter scroll compressors



Danfoss Air Conditioning scroll compressors



Danfoss Heat Pump scroll compressors



Maneurop® Inverter reciprocating compressors



Danfoss Refrigeration scroll compressors



Maneurop® Reciprocating Compressors



Optyma™ & Optyma Plus™ Condensing Units



Light commercial reciprocating compressors (manufactured by Secop)

Our products can be found in a variety of applications such as rooftops, chillers, residential air conditioners, heatpumps, coldrooms, supermarkets, milk tank cooling and industrial cooling processes.

member of:



[www.asercom.org](http://www.asercom.org)

Danfoss Commercial Compressors <http://cc.danfoss.com>

Danfoss can accept no responsibility for possible errors in catalogues, brochures and other printed material. Danfoss reserves the right to alter its products without notice. This also applies to products already on order provided that such alterations can be made without subsequential changes being necessary in specifications already agreed. All trademarks in this material are property of the respective companies. Danfoss and the Danfoss logotype are trademarks of Danfoss A/S. All rights reserved.